

# ARIANA

Cool-Line-System



*This is where it belongs to!*

**CoolLine<sup>®</sup>**

*Cooling Lubricant Hose System*

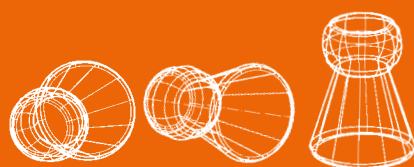

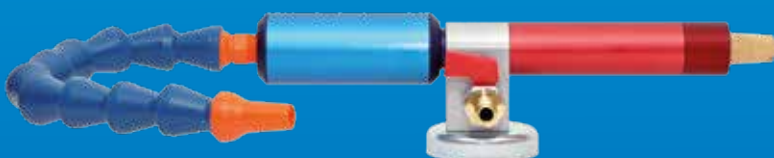



## ARIANA Industrie GmbH

is market leader...

in the field of Cooling

Lubricant Hose Systems with an extensive line accessories for the metal working industry.

ARIANA is accredited by DIN EN ISO 9001:2000.

## Research and Development

Research and development are the first priorities for ARIANA.

A long lasting experience influences all our products. The development takes place in a practical, application-oriented way and is matched to the requirements of its customers.



Our technicians and application engineers are responsible for the optimal adaptability of the ARIANA-Cool-Line-Systems as well as for the implementation of special construction wishes.

## Production

ARIANA disposes through participation in own workshops with latest machinery and production facilities. Flexibility offers short terms of delivery and a permanent control ensures our high norm of quality.



## Cool-Line-System 1/4"

















IT = Inside thread ET = External thread ID = Inner diameter ED = External diameter NPT = Tapered screw thread  
 NPS = Cylindric screw thread  
 Our prices are quoted ex works Schallstadt, zero vated for VAT. See our general sales and payment conditions.

Image	Order no.	Description	unit
	0211000-1	Versatile Jointed Hose 1/4" length approx. 31 cm	2x10 Modules
	0211010-1	Versatile Jointed Hose acid resitant 1/4" length approx. 31cm	2x10 Modules
	0211025-1	Versatile Jointed Hoseoll 1/4" length approx. 25 m (no pic.)	1615 Modules
	0211030-2	Fixing Clamp for 1/4" System	2 Pcs.
	0211100-4	Round Nozzle ID 1,6 mm, 1/4"	4 Pcs.
	0211101-4	Round Nozzle ID 3,2 mm, 1/4"	4 Pcs.
	0211102-4	Round Nozzle ID 6,4 mm, 1/4"	4 Pcs.
	0211104-4	Angle Nozzle 90°, ID 1,6 mm, 1/4"	4 Pcs.
	0211105-4	Angle Nozzle 90°, ID 3,2 mm, 1/4"	4 Pcs.
	0211106-4	Angle Nozzle 90°, ID 6,4 mm, 1/4"	4 Pcs.
	0211200-2	Flare Nozzle IB 27 mm wide, 1/4"	2 Pcs.
	0211201-2	Flare Nozzle IB 32 mm wide, 1/4"	2 Pcs.
	0211202-2	Flare Nozzle 16 hole, 1/4", ID 1 mm	2 Pcs.
	0211206-2	Flare Nozzle 16 hole, 1/4", ID 1,5 mm	2 Pcs.
	0211207-2	Flare Nozzle 16 hole, 1/4", ID 2,0 mm	2 Pcs.
	0211203-2	Flare Nozzle 6 hole, 90°, 1/4"	2 Pcs.
	0211300-2	Y-Fitting 1/4"	2 Pcs.
	0211310-2	Y-Fitting acid resistant 1/4"	
	0211414-1	Ring Jet System 1/4" (16 modules) incl. end piece	1 Pcs.
	0211600-2	Control Valve for Versatile Jointed Hose 1/4"	2 Pcs.
	0211610-2	Control Valve acid resistant for Versatile Jointed Hose 1/4"	2 Pcs.
	0211601-2	Control Valve ET 1/4"	2 Pcs.
	0211611-2	Control Valve acid resistant ET 1/4"	2 Pcs.
	0211602-2	Control Valve IG 1/4"	2 Pcs.
	0211612-2	Control Valve acid resistant IG 1/4"	2 Pcs.
	0211603-2	Control Valve for Versatile Jointed Hose, NPS ET 1/4"	2 Pcs.
	0211700-4	Connector NPT 1/8"	4 Pcs.
	0211710-4	Connector acid resistant NPT 1/8"	4 Pcs.
	0211701-4	Connector 1/4"	4 Pcs.
	0211705-4	Double nipple ET 1/4" . 1.8"	4 Pcs.
	0211706-4	Sleeve 1/4"	4 Pcs.
	0211713-4	Sheathing IG 1/4"	4 Pcs.
	0211702-2	Special Connector NPT 1/8"	2 Pcs.
	0211703-2	Special Connector NPT 1/4"	2 Pcs.
	0211704-4	Adapter for Versatile Jointed Hose IG 1/8"	4 Pcs.
	0211712-4	Adapter acid resistant for Versatile Jointed Hose IG 1/8"	4 Pcs.
	0212200-2	Elbow Fitting 90°, 1/4"	2 Pcs.
	0212300-2	T-Fitting 1/4"	2 Pcs.



## Cool-Line-System 1/4"

IT = Inside thread ET = External thread ID = Inner diameter ED = External diameter NPT = Tapered screw thread  
 NPS = Cylindric screw thread  
 Our prices are quoted ex works Schallstadt, zero vated for VAT. See our general sales and payment conditions.

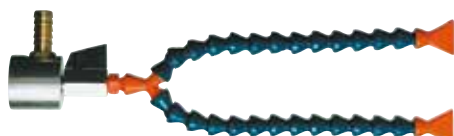
Image	Order no.	Description	unit
	0212400-1	Modular Manifold Brackets for T-Fitting 1/4"	1 Pcs.
	0212500-1	Magnetic Base Metal Ball Valve and Hose Barb Connector 1/4"	1 Pcs.
	0212501-1	Mono Block Distribution Device 4 outlets 1/4" and IG 3/8"	1 Pcs.
	0212502-2	T-Connection AG 1/4" und 2 IG 3/8"	2 Pcs.
	0212503-2	Metal Ball Valve IG und AG 1/4"	2 Pcs.
	0212504-2	Threaded Double Nipple 2 AG 1/4"	2 Pcs.
	0212505-2	Hose Barb Connector 1/4" for 13mm hose	2 St
	0212506-2	Metal Reducer AG 1/4", IG 1/8"	2 Pcs.
	0212507-2	Hexagonal Closing Cap 1/8"	2 Pcs.
	0212508-2	Hexagonal Closing Cap 1/4"	2 Pcs.
	0212509-2	Magnetic Clamp round, OD 63 mm, ID 18 mm	2 Pcs.
	0212510-2	Non-Return Valve 1/4"	2 Pcs.
	0212605-2	Extension Pipe rigid-PVC, 95 mm lg., 1/4"	2 Pcs.
	0218000-1	Hose Assembling Pliers 1/4" system	1 Pcs.
	0219000-1	Versatile Jointed Hose Set 1/4" with Versatile Jointed Hose [2x 10 modules], Round Nozzles ID 1,6 / 3,2 / 6,4 mm, Flare Nozzle 24 mm breit, Connectors NPT 1/8" / 1/4"	1 Set
	0219029-1	Magnetic Base 1/4" with Versatile Jointed Hose Set [16 modules], Round Nozzle ID 6,4 mm, Connector NPT 1/4", Metal Ball Valve IG-AG 1/4", Magnetic Base 2 IG 90°, Hose Barb Connector for 13 mm	1 Set
	0219031-1	Magnetic Base 1/4" mit Gelenkschlauch-Set Flare Nozzle (2 pcs., IB 24 mm wide), Y-Fitting, Connector NPT 1/4", Metal Ball Valve IG-AG 1/4", Magnetic Base 2 IG 90°, Hose Barb Connector for 13 mm hose	1 Set



## Cool-Line-System 3/8

IT = Insie thread ET = External thread ID = Inner diameter ED = External diameter NPT = Tapered screw thread  
 NPS = Cylindric screw thread  
 Our prices are quoted ex works Schallstadt, zero vated for VAT. See our general sales and payment conditions.

Image	Order no.	Description	unit
	0221000-1 0221015-1	Versatile Jointed Hose 3/8" length approx. 30 cm Versatile Jointed Hoseroll 3/8" length approx. (without picture)	2x 8 Module 802 Module
	0221100-4 0221101-4 0221102-4	Round Nozzle ID 6,4 mm, 3/8" Round Nozzle ID 9,5 mm, 3/8" Round Nozzle ID 12,7 mm, 3/8"	4 Pcs. 4 Pcs. 4 Pcs.
	0221200-2	Flare Nozzle 32 mm wide, 3/8"	2 Pcs.
	0221601-2 0221602-2	Control Valve NPT AG 3/8" Control Valve IG 3/8"	2 Pcs. 2 Pcs.
	0221700-4 0221701-4	Connector NPS 3/8" Connector NPS 1/2"	4 Pcs. 4 Pcs.
	0222501-1	Mono Block Distribution Device 4 outlets 3/8" and IG 1/2"	1 Pcs.
	0222502-2	T-Connection AG 3/8" and 2 IG 3/8"	2 St
	0222503-2	Metal Ball Valve IG and AG 3/8"	2 Pcs.
	0222504-2	Threaded Double Nipple 2 AG 3/8"	2 Pcs.
	0222505-2	Hose Barb Connector 3/8" for 13mm hose	2 Pcs.
	0222504-2	Hose Barb Connector 3/8"	2 Pcs.
	0222508-2	Hexagonal Closing Cap round AD 63 mm, ID 18 mm	2 Pcs.
	0222509-2	Non-Return Valve 3/8"	2 Pcs.
	0228000-1	Hose Assembling Pliers 3/8" system	1 Pcs.
	0229000-1	Versatile Jointed Hose Set 3/8" Versatile Jointed Hose ( 2x 8 module ) Flare Nozzle 32 mm wide Connectors NPS 3/8" / 1/2"	1 Set
	0229030-1	Magnetic Base 3/8" with Versatile Jointed Hose-Set (16 modules) Round Nozzles ID 6,4 mm, Connector 3/8" Metal Ball Valve IG-AG 3/8", magnetic Base 2 IG 3/8" Hose Barb Connector 3/8" for 13 mm hose	1 Set



## Cool-Line-System 1/2"

IT = Insie thread ET = External thread ID = Inner diameter ED = External diameter NPT = Tapered screw thread  
 NPS = Cylindric screw thread  
 Our prices are quoted ex works Schallstadt, zero vated for VAT. See our general sales and payment conditions.

Image	Order no.	Description	unit
	0231000-1 0231001-1 0231010-1 0231015-1	Versatile Jointed Hose 1/2" length approx. 29 cm Versatile Jointed Hose extrem fest 1/2" c 28 cm Versatile Jointed Hose acid resistant 1/2" Versatile Jointed Hoseroll 1/2" length approx. 15 m	2 x 5 Module 2 x 6 Module 2 x 5 Module 518 Module
	0231030-2	Fixing Clamp for 1/2" system	2 Pcs.
	0231100-4 02311000-4 0231101-4 02311001-4 0231102-4 02311002-4	Round Nozzle ID 6,4 mm, 1/2" Round Nozzle acid resistant ID 6,4 mm, 1/2" Round Nozzle ID 9,5 mm, 1/2" Round Nozzle acid resistant ID 9,5 mm, 1/2" Round Nozzle ID 12,7 mm, 1/2" Round Nozzle acid resistant ID 12,7 mm, 1/2"	4 Pcs. 4 Pcs. 4 Pcs. 4 Pcs. 4 Pcs.
	0231104-4 0231105-4 0231106-4	Angle Nozzle 90° ID 6,4 mm Angle Nozzle 90° ID 9,5 mm Angle Nozzle 90° ID 12,7 mm	4 Pcs. 4 Pcs. 4 Pcs.
	0231200-2 0231201-2	Flare Nozzle IB 35 mm wide, 1/2" Flare Nozzle IB 50 mm wide, 1/2"	2 Pcs. 2 Pcs.
	0231202-2 0231203-2	Flare Nozzle IB 63 mm wide 1/2" Flare Nozzle 8 holes 90°, 1/2"	2 Pcs. 2 Pcs.
	0231300-2	Y-Fitting 1/2"	2 Pcs.
	0231414-1	Ring Jet System (16 modules ) incl. end piece 1/2"	1 Pcs.
	0231600-2 0231610-2	Control Valve for Versatile Jointed Hose 1/2" Control Valve acid resistant for Versatile Jointed Hose 1/2"	2 Pcs. 2 Pcs.
	0231601-2 0231611-2 0231602-2 0231612-2	Control Valve NPT AG 1/2" Control Valve acid resistant NPT AG 1/2" Control Valve acid resistant NPT AG 1/2" Control Valve acid resistant IG 1/2"	2 Pcs. 2 Pcs. 2 Pcs. 2 Pcs.
	0231700-4 02317000-4 0231701-4 02317001-4	Connector NPT 3/8" Connector acid resistant NPT 3/8" Connector NPT 1/2" Connector acid resistant NPT 1/2"	4 Pcs. 4 Pcs. 4 Pcs. 4 Pcs.
	0231702-2 0231703-2	Connector NPT 1/2" Connector acid resistant NPT 1/2"	2 Pcs. 2 Pcs.
	0231704-2	Sleeve 1/2"	2 Pcs.
	0231707-4	Adapter Versatile Jointed Hose IG 1/2"	4 Pcs.
	0231713-4	Sheathing IG 1/2"	4 Pcs.
	0231900-2 0232000-2	Reducer 1/2" to 1/4" Y-Reducer 1/2" to 2x 1/4"	2 Pcs. 2 Pcs.



## Cool-Line-System 1/2"

IT = Inside thread ET = External thread ID = Inner diameter ED = External diameter NPT = Tapered screw thread  
 NPS = Cylindric screw thread  
 Our prices are quoted ex works Schallstadt, zero vated for VAT. See our general sales and payment conditions.

Image	Order no.	Description	unit
	0232200-2 0232300-2	Elbow Fitting 90°, 1/2" T-Fitter 1/2"	2 Pcs.
	0232400-1	Modular Manifold Brackets for T-Fitting 1/2"	1 Pcs.
	0232501-1	Mono Block Distribution Device 4 outlets 1/2" und IG 3/4"	1 Pcs.
	0232502-2	T-Connection AG 1/2" and 2 IG 1/2"	2 Pcs.
	0232503-2	Metal Ball Value IG and AG 1/2"	2 Pcs.
	0232504-2	Threaded Double Nippel 2 AG 1/2"	2 Pcs.
	0232505-2	Horse Barb Connector for 19 mm hose	2 Pcs.
	0232506-2	Metal Reducer AG 1/2", IG 3/8"	2 Pcs.
	0232507-2	Hexagonal Closing Cap 1/2"	2 Pcs.
	0232508-2	Magnetic Base round ED 63 mm, ID 18 mm	2 Pcs.
	0232509-2	Non Return Valve 1/2"	2 Pcs.
	0232510-2	Non Return Valve 1/2"	2 Pcs.
	0232605-2	Check Valve	2 Pcs.
	0238000-1	Hose Assembling Pliers 1/2" system	1 Pcs.
	0239000-1	Versatile Jointed Hose Set 1/2" (2x 5 modules) Round Nozzles ID 6,4 / 9,5 / 12,7 mm Flare Nozzles 32 mm wide Connectors NPT 3/8" / 1/2"	1 Set





## Cool-Line-System 3/4"

IT = Insie thread ET = External thread ID = Inner diameter ED = External diameter NPT = Tapered screw thread  
 NPS = Cylindric screw thread  
 Our prices are quoted ex works Schallstadt, zero vated for VAT. See our general sales and payment conditions.

Image	Order no.	Description	unit
	0241000-1 0241015-1	Versatile Jointed Hose 3/4" length approx. 29,5 cm Versatile Jointed Hoseroll 3/4" length approx. 15 m ( without picture )	2 x 5 Module 509 Module
	0241100-4 0241101-4	Round Nozzle ID 16 mm, 3/4" Round Nozzle ID 19 mm, 3/4"	4 Pcs. 4 St
	0241200-2	Flare Nozzle 75 mm wide, 3/4"	2 Pcs.
	0241300-2	Y-Fitting 3/4"	2 Pcs.
	0241700-4	Connector NPS 3/4"	4 Pcs.
	0241900-2	Reducer 3/4" to 1/2"	2 Pcs.
	0242507-2	Threaded end cap 3/4"	2 Pcs.
	0242512-1	Metal ball valve 3/4"	1 Pcs.
	0248000-1	Hose Assembling Pliers 3/4" system	1 Pcs.
	0249000-1	Versatile Jointed Hose Set 3/4" Versatile Jointed Hose (2x 5 modules) Round Nozzles ID 16 / 19 mm Flare Nozzles 75 mm wide Connector NPS 3/4"	2 Pcs.
	0259000-1	Display	1 Pcs.
	0271000-1 0271001-1 0271002-1	protective shield (complete), 300 x 220mm protective shield (complete), 250 x 200mm protective shield (complete), 200 x 150mm	1 Pcs. 1 Pcs. 1 Pcs.



## Comparison of compatibility

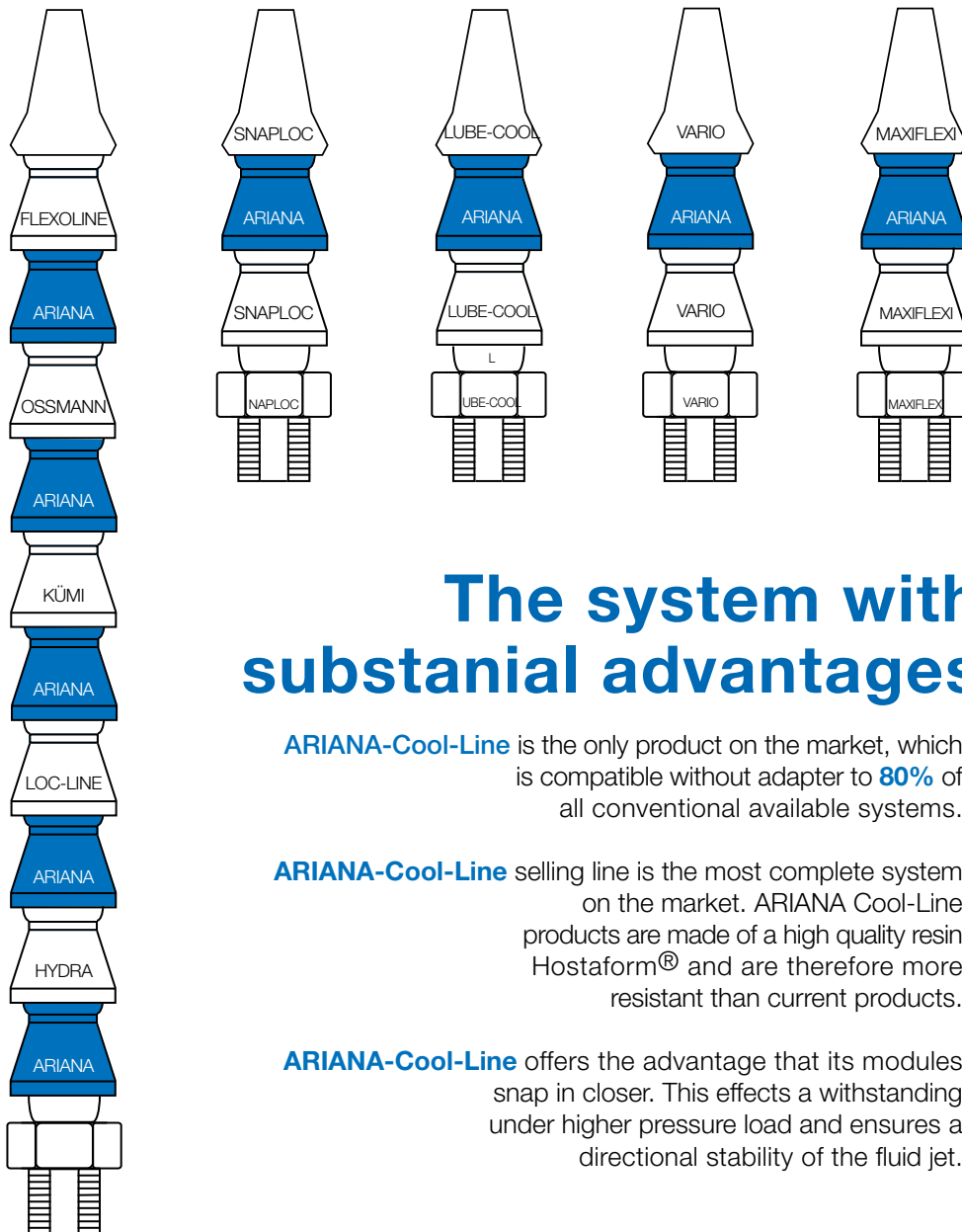

## The system with substantial advantages

**ARIANA-Cool-Line** is the only product on the market, which is compatible without adapter to **80%** of all conventional available systems.

**ARIANA-Cool-Line** selling line is the most complete system on the market. ARIANA Cool-Line products are made of a high quality resin Hostaform® and are therefore more resistant than current products.

**ARIANA-Cool-Line** offers the advantage that its modules snap in closer. This effects a withstanding under higher pressure load and ensures a directional stability of the fluid jet.



## Emulsion care case

### Contents:

- Thermometer for determination of sample temperature
  - Nitrite test strips (100 pcs)
  - Nitrate test strips (100 pcs)
  - Ph test strips (100 pcs)
  - Water hardness test strips (100 pcs)
  - Plastic cup for extraction of samples
  - Plastic bottles for extraction of samples (3 pcs)
- 
- Care plan for cooling lubricants
  - Maintenance plan
  - Technical regulations TRGS 611
  - Manual for handheld refractometer  
(see inside the cover under the protective foam)



Order no. 0292000 Emulsion care case without handheld refractometer  
Order no. 0292001 Emulsion care case with handheld refractometer



## Test Materials / Indicators

for Protection and Monitoring Measures According to TRGS 611

### Ph – Indicators 7.0 – 14.0

Submerge the test strip in the emulsion, wait a few seconds, then hold it up to the colour-coded comparison chart and read the results.

Order no. 0292050 (100-strip pack)



### Nitrite test strips 0 - 25 mg/l

Submerge the test strip in the emulsion and after approx. 30 seconds hold it up to the colour-coded comparison chart and read the results. The presence of nitrite ions is indicated by a change in colour to red.

Order no. 0292051 (100-strip pack)





## Nitrite + ph test strips

Order No. 0292061 (100-strip pack)



## Nitrate test strips 0 - 500 mg/l

Submerge the test strip in the emulsion and after approx. 30 seconds hold it up to the colour-coded comparison chart and read the results.

The presence of nitrate ions is indicated by a change in colour to red.

Order no. 0292052 (100-strip pack)



## Water hardness test strips 0 - 28° dH (German degrees)

Submerge the test strip in the water and after approx. 30 seconds hold it up to the colour-coded comparison chart and read the results.

You can determine the water hardness based on the change in colour.

Order no. 0292053 (100-strip pack)





## Kombi-Micro-Dipslides

ARIANA Kombi-Micro-Dipslides are test strips for the determination of bacteria and fungi in cooling lubricants during the different processing procedures. These test strips are a valuable tool to prevent health risks caused by spray mist or droplet formation.

ARIANA Kombi-Micro-Dipslides (culture medium) allow fluids to be easily tested to determine the colony-forming units (CFU) and to take suitable counter-measures. Results regarding bacteria are provided within 48 hours. The detection of fungi is shown after 72 hours.

For quick cultivation / incubation of the medium, we recommend using an incubator. This is the prerequisite for testing the growth of the cultures. We recommend a temperature of approx. 30°C. The ARIANA Kombi-Micro-Dipslide with the light-coloured surface is for the detection of bacteria, and the one with the reddish surface is for the detection of fungal infestation.

The results can be easily read by comparing the incubated ARIANA Kombi-Micro-Dipslide with the template. For further information see attached operating manual.

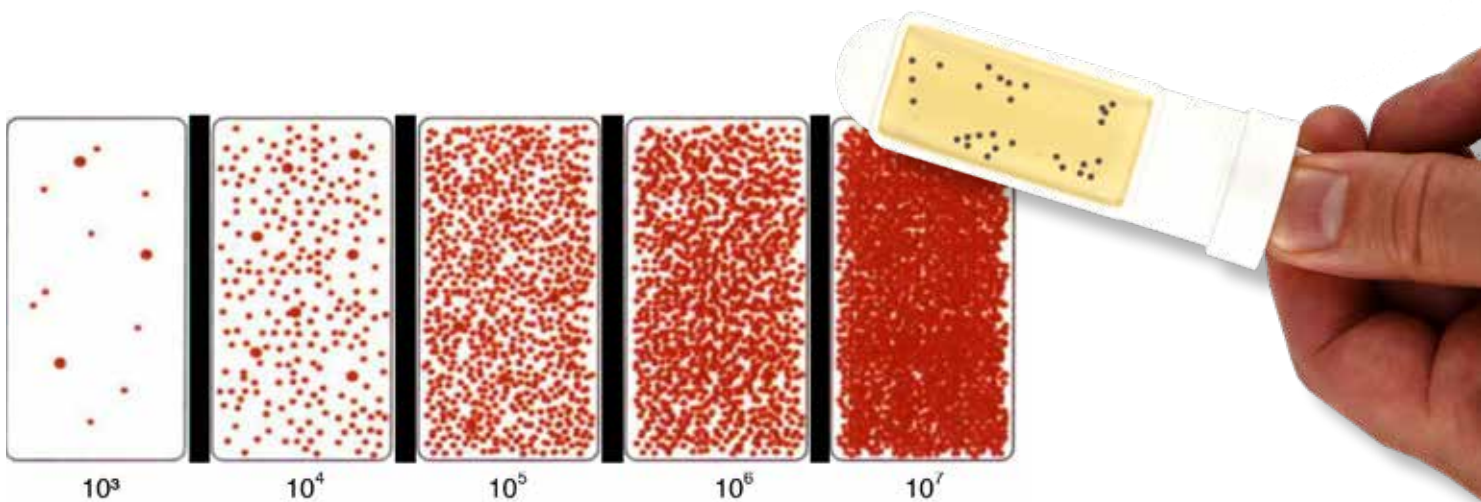



## ARIANA Incubator for Kombi-Micro-Dipslides

ARIANA incubator is suitable for small laboratories or rapid analysis at customer's site for determination of mould, bacteria or yeast.

Temperature is pre-set to 30°C. The incubator is for 2 Kombi-Micro-Dipslides. To read the result please compare the incubated Dipslides with the comparative table.



Item No. 0292055.1

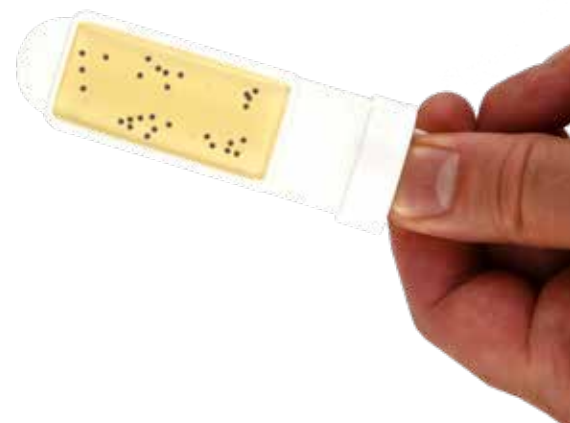
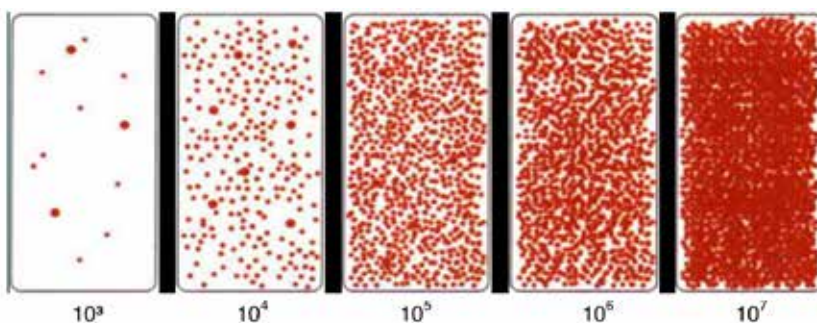



## Handheld Refractometer



Order no. 0521000 (0 - 32°)  
Order no. 0521001 (0 - 15°)

The [ARIANA Handheld Refractometer](#) is an essential instrument for checking emulsions and grinding solutions. It allows for quick measurement of the emulsion concentration of liquid coolants and lubricants. In this way, liquids always have the optimum concentration.

### This provides the following advantages:

- Better utilisation of machine tools
- Longer tool service life
- Prevention of rust as a result of using emulsions that are too weak
- It is possible to adjust the concentration of the emulsion to suit requirements (TRGS-611)
- Cost reduction

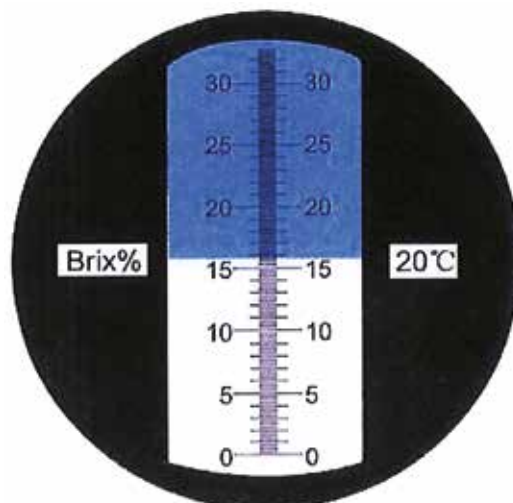

The scale of the handheld refractometer is well-lit and readily legible.





## Digital Hand Refractometer



Order no. 0512005 (0 – 70°)

[ARIANA-Digital Hand Refractometer](#) is an important instrument for controlling emulsions and grinding abrasives. It allows quick control of the emulsion concentration of cooling and lubrication liquids. Thus it becomes possible to use these liquids at optimum concentrations.

### Following advantages will be achieved:

- Better utilization of tooling machines
- Longer service life of tools
- Avoiding rust because of too low grade of emulsion
- Possibility to vary the grade of emulsion concentrate according to requirements (TRGS- 611)
- Reduction of costs

The concentration can be read on the display of the hand refractometer.



## Special Mono Mixing Unit

A mixing unit is essential for mixing emulsions and grinding solutions. By means of a needle valve, the [ARIANA Special Mono Mixing Unit](#) allows for fast and precise adjustment of the emulsion concentration of liquid coolants and lubricants. In this way, it is possible to mix liquids using optimum concentrations.



Order no. 0512002

Special Mono Mixing Unit with barrel lid screw connection

The Special Mono Mixing Unit has one water inlet and one concentrate inlet. Once the optimum mixing ratio has been determined, the user can always rely on this ratio being the case. Of course, it is possible to change the mixing ratio at any time. For safety reasons, a return valve is installed on the water inlet side to prevent any suctioning into the potable water system.

The Special Mono Mixing Unit is the simplest version in the mixing unit range. Quick and simple installation on a barrel is possible thanks to the barrel lid screw connection set. The unit is compact and extremely easy to handle.



### Technical data

Water inlet	1/2"
Concentrate inlet	3/8"
Mixed liquid outlet	1/2"
Mixing volume (approx.) l/h	270



## Mono Mixing Unit

A mixing unit is essential for mixing emulsions and grinding solutions. By means of a needle valve, the **ARIANA Mono Mixing Unit** allows for fast and precise adjustment of the emulsion concentration of liquid coolants and lubricants. In this way, it is possible to mix liquids using optimum concentrations.

The Mono Mixing Unit has one water inlet and one concentrate inlet. Once the optimum mixing ratio has been determined, the user can always rely on this ratio being the case. Of course, it is possible to change the mixing ratio at any time. For safety reasons, a return valve is installed on the water inlet side to prevent any suctioning into the potable water system.



Order no. 0512000

The Mono Mixing Unit is the simplest version in the mixing unit range. Quick and simple installation at a barrel is possible thanks to the barrel lid screw connection set. The unit is compact and extremely easy to handle.



### Technical data

Water inlet	1/2"
Mixed liquid outlet	1/2"
Concentrate inlet	3/8"
Mixing volume (approx.) l/h	540



## Duo Mixing Unit



Order no. 0511000

A mixing unit is essential for mixing emulsions and grinding solutions. By means of two needle valves, the ARIANA Duo Mixing Unit permits fast and precise adjustment of the emulsion concentration of liquid coolants and lubricants. In this way, it is possible to produce liquids using optimum concentrations.

The Duo Mixing Unit has one water inlet and two concentrate inlets. Once the optimum mixing ratio has been determined, the user can always rely on this ratio being the case. Of course, it is possible to change the mixing ratio at any time. For safety reasons, a return valve is installed on the water inlet side to prevent any suctioning into the potable water system.

Unlike the Mono Mixing Unit, the Duo Mixing Unit has two concentrate inlets. This makes it possible to mix two different concentrates without having to reposition the mixing unit.



### Technical data

Water inlet	1/2"
Mixed liquid outlet	1/2"
Concentrate inlet	3/8"
Mixing volume (approx.) l/h	540



## Piston Mixer

A mixing unit is essential for mixing emulsions and grinding solutions. The recently developed [ARIANA Piston Mixer](#) is powered by water pressure; which causes the concentrate to be suctioned..



It is possible to set the required emulsion concentration of the liquid coolant and lubricant by means of the dosing screw. These liquids can thus be mixed using optimum concentrations. Once the optimum mixing ratio has been determined, the user can always rely on this ratio being the case. Of course, it is possible to change the mixing ratio at any time.

The Piston Mixer has one water inlet, one concentrate inlet and an outlet hose for the mixed emulsion or grinding solution. This hose can be extended indefinitely without resulting in a vacuum in the system.

For safety reasons, we recommend installing a system separator (set of non-return valve) in front of the water inlet in order to protect against water contamination.

The mixer is mounted using a wall bracket. The mixer is extremely handy and compact.

The suction hose and the suction sieve is being delivered together with the mixer.

Order no. 0514000	Mixing volume (approx.) l/h 600
Order no. 0514001	Mixing volume (approx.) l/h 2.000
Order no. 0514002	Mixing volume (approx.) l/h 10.000



Kit containing „set of non-return valve“  
Item n° 0514010 containing

- pressure decreasing device
- non return valve
- double nipple 3/4"
- ball valve 3/4"
- sleeve



## Hose Reel System with Hose Nozzle

Order no. 0555000



- Ideal accessory for the [ARIANA piston mixer](#)
- Rugged steel sheet design
- Holder for wall mounting, ceiling or floor
- High quality drive springs for long service life
- Automatic catch
- Rubber limit stop for individual adjustment of hose length off the reel
- Pump performance from 90 l/min up to 20 bars possible
- Due to automatic hose nozzle it is quite easy to refuel vehicles or machines
- Hose nozzle features an automatic switch off system
- A pivot joint with 1 inch female thread gives the nozzle more flexibility

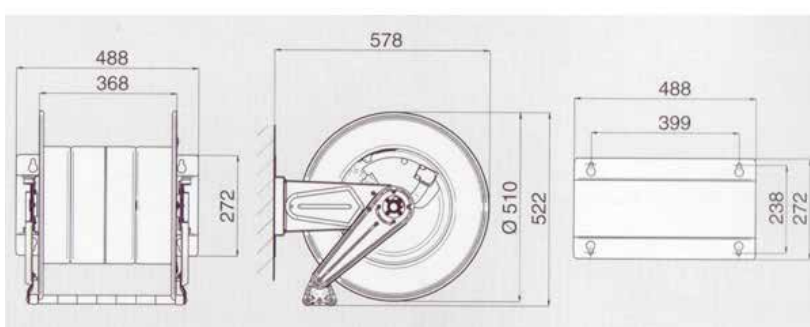



## Hose Skimmer

Leak oils promote bacterial growth, form deposits on machine tools and work pieces, cause oil mist and reduce cooling capacity as well as the oxygen absorption of the emulsion. The consequences: higher costs for waste disposal, corrosion, bacterial contamination, unpleasant odours, poor cooling effect, skin problems, etc.

The [ARIANA Hose Skimmer](#) provides a solution by removing the oil that collects on the surface of the emulsion. The leak oil is removed from the surface and sloughed off in the unit by means of special self-cleaning, oil-conveying hoses. There is no need for filters or microporous membranes. This results in lower operating and follow-up costs. The hose skimmer has an oil separating unit and ensures that up to 90% of tramp oil is removed.



The hose skimmer is attached above the basin by means of a magnetic plate, ideally on the side opposite the liquid inlet. The base plate of the drive unit must be positioned about 300 mm above the maximum level of the liquid. The hose is positioned at the outlet support and fed into a sedimentation basin.

The hose skimmer can be used for continuous operation or controlled by means of a timer. Use of the unit during operation of the tool machine is recommended.

The hose moves through the floating oil film and separates it from the liquid. The oil is sloughed off in the unit and flows into a collecting tank outside the machine.

Order no. 0541250

### Technical data

Electric connection with level switch	V	230
Weight	kg	3
Hose diameter	mm	10
Capacity (approx.)	l/h	5



## Ariana KSS emulsifier aerator

The emulsifier aerator ensures a high quality coolant by the entry of atmospheric oxygen.

By the supply of oxygen and the rising air bubbles a circulation of the cooling lubricant emulsion is produced, and the impurities such as foreign oils and suspended particles can be removed from the surface, to reduce the risk of bacterial contamination.

A belt skimmer or a maintenance system R-2000 / R-3000 can here be used to separate and remove the impurities. Because of its easy installation and operation, and through a timer, the KSS emulsion aerator can be used quickly and appropriately. This way, you get a powerful coolant with an excellent life expectancy.



top view

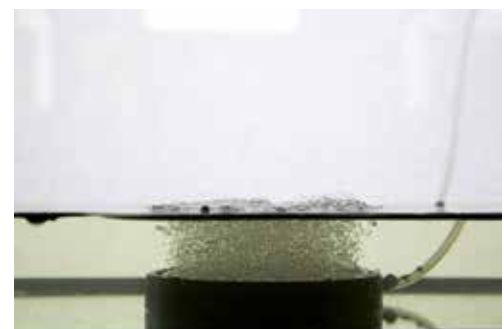

sideview

### Ariana KSS-emulsifier aerators in 3 types

Order no.

0541010 KSS emulsifier aerator upto 350 litres Container

0541011 KSS emulsifier aerator upto 500 litres Container

0541012 KSS emulsifier aerator upto 1000 Litre Container





## Liquid level indicator



Order no. 0513507

Liquid level indicator: usable for commercial 60 l and 210 l barrels. Suitable for non corrosive liquids, such as cooling/lubrication concentrates, emulsions, oils, anti freeze, heating oil etc. and liquid media.

Ideally usable for more transparency when handling the barrel. The float is located inside the barrel on the liquid and indicates the barrel content permanently on the volume scale.

Since the Liquid level indicator is mounted on the 3/4" opening you can put a pump on the 2"- bung hole at the same time, in order to allow pumping out the defined quantity.



## Deburring tools

- With changeable blade, prolongable about 125 mm, for easy and average deburring processes. All-purpose handle with end cap and room to store spare blades.
- Deburring Tool is complete with handle, holder and 10 blades A-100 for steel, aluminum, brass and plastic materials. Mountable with blades as can be seen in the table.

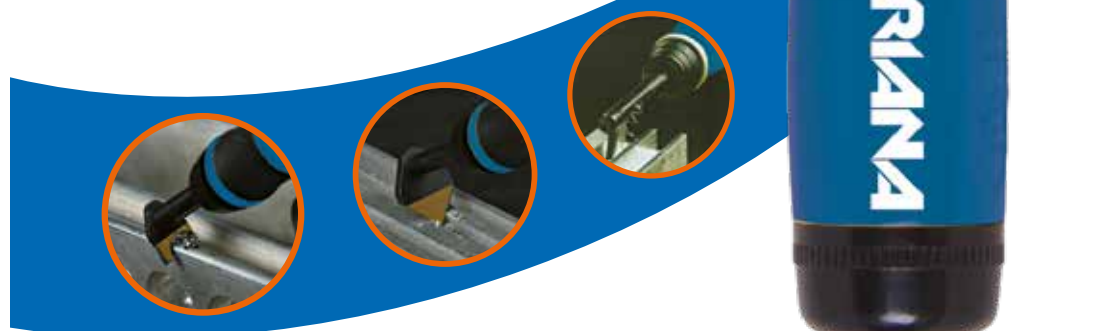

0554000 (Deburring Tool Set)



## Blades for deburring tool



Straight edge
Hole edge
Cross hole - both edges
Cross bore - both edges
Hole - inner surface
Even surface
Steel
Aluminium
Copper
Brass
Casting
Stainless steel
Acetal
Plastic

▲ = well suited  
 ▲▲ = very well suited

Item num.	Figure	Blade	Application						Material						Description	
0554030		A100	▲▲						▲▲	▲▲	▲▲					HSS blade for difficult deburring tasks Deburring of materials causing helicoidal chips.
0554031		A101	▲▲											▲▲	▲▲	HSS blade for deburring of holes with diameter up to 7 mm.
0554032		A200	▲▲									▲▲	▲▲			HSS blade for materials causing short chips. Turns clockwise and anticlockwise.
0554034		A300		▲					▲▲	▲▲	▲▲					HSS blade for materials with helicoidal chips. Deburrs simultaneously in- and outside of holes with diameter up to 6 mm.
0554035		R10	▲▲						▲▲	▲▲	▲▲					Standard HSS blade for deburring of inside and outside edges.
0554036		R20	▲▲									▲▲	▲▲			HSS blade for brass and cast iron which can be used in either direction.
0554037		R30		▲					▲▲	▲▲	▲▲					HSS blade for deburring of thin-wall materials, inside and outside.
0554039		T25			▲	▲	▲		▲▲	▲▲	▲▲	▲	▲	▲		ø 4,0 x 25 mm, triangular HSS scraper for precision working, M5
0554040		K20		▲					▲▲	▲▲	▲▲	▲	▲	▲		Countersunk head for holes up to 20 mm diameter, M7
0554041		K30		▲					▲▲	▲▲	▲▲	▲	▲	▲		Countersunk head for holes up to 30 mm diameter, M7



## R-1000 Maintenance Station for Cooling Lubricants

Contamination of cooling lubricants by tramp oils and solid particles during the production process is inevitable. The ARIANA R-1000 Maintenance Station provides optimum cleaning and maintenance of emulsions or solutions during production. This considerably prolongs the working life of lubricants and tools and reduces disposal costs to a minimum.

### Areas of use

- Lathes
- Milling machines
- Grinding machines
- Parts washers
- Quenching tanks

### Advantages

- Removes tramp oils
- Works automatically without an operator using the bypass principle
- Stops the formation of odours and the risk of infection
- Prolongs the working life of lubricants and tools
- Reduces disposal costs



### Application

Cooling lubricants in wet-cutting machines are subject to serious contamination. Externally supplied hydraulic oils, bedway oils and grease collect on the surface of the emulsion and, in high concentrations, prevent the vital exchange of oxygen. Combined with floating and deposited solids, this then provides the ideal breeding ground for bacteria and fungi which cause the cooling lubricant to deteriorate. Constant maintenance with the regular removal of these contaminants considerably extends the working life of the cooling lubricant and reduces disposal costs.

### How it works

The ARIANA R-1000 maintenance stations suction off a mixture of oils and solid particles from the surface of the emulsion. This mixture is separated in the maintenance station, the cleaned emulsion is passed back into the machine tool and the separated oil is passed to a separate disposal container. The emulsion and oils are separated purely physically so gently that the emulsion is not damaged by spinning, etc.. 97% of tramp oils which float up and swirl around are removed. The emulsion is cleaned without the need for an operator while the machine tool is working. There is no need for any down time.

### Technical data

Size:	270 mm wide, 440 mm high, 152 mm deep
Weight:	15 kg
Material:	V2a quality 1.4301
Pump:	Impeller pump
Flow:	80 – 350 l/h, adjustable
Voltage:	230V/50Hz



## Maintenance Station R-2000 for Cooling Lubricants

Cooling lubricants inevitably become contaminated with tramp oils and particulate matter during the production process.

The [ARIANA Maintenance Station R-2000](#) makes it possible to clean and maintain emulsions or solutions during the production process. This greatly prolongs the service life and minimizes disposal costs.

### Application areas

- Lathes
- Milling machines
- Grinding machines
- Parts washers
- Quenching boxes

Order No. 0541020



### Advantages

- Removes tramp oils and particulate matter simultaneously
- Works automatically without an operator using the bypass principle
- Prevents unpleasant odours and risk of infection
- Increases the service life of lubricants and tools
- Reduces disposal costs



## Application

Cooling lubricants in wet-cutting machines are subject to high levels of contamination. Hydraulic oil, bedway oil and grease collect on the surface of the emulsion and, in high concentrations, prevent the necessary exchange of oxygen.

In connection with floating and deposited particulate matter, this provides an ideal breeding ground for bacteria and fungi, which degrade the cooling lubricant.

Ongoing maintenance with removal of these contaminants at regular intervals considerably prolongs the service life of the cooling lubricant and lowers disposal costs.

## How it works

The [ARIANA Maintenance Station R-2000](#) suctions off a mixture of oils and particulate matter from the surface of the emulsion.

This mixture is separated in the maintenance station, the cleaned emulsion is conducted back into the machine tool and the separated oil is collected in a separate disposal container.

The process of separating the emulsion and oil is purely physical and is so gentle that the emulsion is not negatively affected, e.g. as it would be a result of spinning. 97% of floating trash oil and trash oil subjected to turbulence is removed.

The emulsion is cleaned without the presence of an operator and without interrupting operation of the machine tool. No down time occurs.

## Technical features

Eccentric worm pump

Electric motor

Made of stainless steel material with powder coating

All hose connections with fast-action single-hand connectors

Station is completely assembled and ready for use, complete with accessories

### Technical data

Motor capacity	kWh	0.37
Voltage	V	230
Flow rate	l/h	350
Dimensions	mm	860 x 830 x 440 (H x L x W)
Weight empty	kg	65
Temperature of liquid	°C	40 (max.)
Filter fineness	(standard)	100 µ



## Maintenance Station R-3000 for Cooling Lubricants

Cooling lubricants inevitably become contaminated with tramp oil and particulate material during the production process.

The [ARIANA Maintenance Station R-3000](#) makes it possible to clean and maintain emulsions or solutions during the production process. This greatly prolongs the service life and minimizes disposal costs.

### Application areas

- Lathes
- Milling machines
- Grinding machines
- Parts washers
- Quenching boxes

Order no. 0541000



### Advantages

- Removes tramp oil and particulate matter simultaneously
- Works automatically without an operator using the bypass principle
- Prevents unpleasant odours and risk of infection
- Increases the service life of lubricants and tools
- Reduces disposal costs



## Application

Cooling lubricants in wet-cutting machines are subject to high levels of contamination. Hydraulic oil, bedway oil and grease collect on the surface of the emulsion and, in high concentrations, prevent the necessary exchange of oxygen.

In connection with floating and deposited particulate matter, this provides an ideal breeding ground for bacteria and fungi, which degrade the cooling lubricant.

Ongoing maintenance with removal of these contaminants at regular intervals considerably prolongs the service life of the cooling lubricant and lowers disposal costs.

## How it works

The [ARIANA Maintenance Station R-3000](#) suctions off a mixture of oils and particulate matter from the surface of the emulsion.

This mixture is separated in the maintenance station, the cleaned emulsion is conducted back into the machine tool and the separated oil is collected in a separate disposal container.

The process of separating the emulsion and oil is purely physical and is so gentle that the emulsion is not negatively affected, e.g. as it would be a result of spinning. 97% of floating trash oil and trash oil subjected to turbulence is removed.

The emulsion is cleaned without the presence of an operator and without interrupting operation of the machine tool. No down time occurs.

## Technical features

Eccentric worm pump

Electric motor

Made of stainless steel material with powder coating

All hose connections with fast-action single-hand connectors

Station is completely assembled and ready for use, complete with accessories

## Technical data

Motor capacity	kWh	0.37
Voltage	V	230
Flow rate	l/h	550
Dimensions	mm	860 x 1200 x 470 (H x L x W)
Weight empty	kg	86
Temperature of liquid	°C	40 (max.)
Filter fineness	(standard)	100µ





## Magnetic filter for ARIANA maintenance stations R-2000 / R-3000



Order No. 0541219

The [ARIANA Magnetic Filter](#) serves as add-on kit for our maintenance stations for cooling lubricants R-2000 und R-3000 as well as for other devices.

Contaminated fluid enters the inlet port where it is equally dispersed by the unique tapered radial flow channels. Fluid then passes down the outside of the centrally mounted magnetic core where contamination particles are attracted.

The geometry of the magnetic flux circuit ensures a controlled build up of the contamination. As a result the filter never blocks.

Benefits:

- Submicron filtration
- Suitable to retrofit ARIANA's R-2000 and R-3000 already in operation
- Easy and quick cleaning
- High intensity magnetic core
- Excellent filtration efficiency



Cleaning:

Using the supplied cleaning tool a fully contaminated core can be cleaned in 30 seconds.



## Cleaning System - Oil Filter Unit



Order no. 0541030

The [ARIANA oil filter unit](#) filters hydraulic oil (at operating viscosities of up to 250 mm<sup>2</sup>/s) and cleans up contamination resulting from particulate matter or silting.

### Usage and application areas

Intermittent cleaning of hydraulic oils in order to meet target category purity levels.  
Prevention of dirt from entering when system is filled.

### Advantages

- Prolongs oil service life
- Reduces disposal costs
- Protects machine components

### Technical data

Electro motor with gerotor pump motor capacity	230 V 50 Hz
Capacity	up to 16 l/min
Operating pressure	up to 4 bar
Filter fineness	3, 5, 12 μ
Contamination indicator	pressure gauge



## Hot & Cold Gun



Order no. 0331000

The [ARIANA Hot & Cold Gun](#) uses compressed air for point-specific heating or cooling of metal and plastic parts at tool machines and features dual functionality: it generates hot as well as cold air. Hot air is used for fast drying and heat treating. Cold air is mainly used in applications in which lubricants and coolants are not recommended. The Hot & Cold Gun is also widely used in laboratories.

The performance of the Hot & Cold Gun varies depending on the humidity of the supplied compressed air: at a pressure 8 bar with relatively dry air (e.g. at +10°C) it is possible to cool supplied air down to -30°C and heat it up to +60°C.

The accessories for the Hot & Cold Gun include the flexible [ARIANA Cool Line System](#).



## Cold Air Nozzle



Order no. 0331001

The [ARIANA-Cold Air Nozzle](#) is used for cooling locations of metal and plastic parts on machine tools and features a double function: it generates both hot and also cold air. The cold air is primarily used at locations where no lubricants and cooling liquids are wanted. The Ariana cold air nozzle is also widely used in laboratories.

The [ARIANA-Cold Air Nozzle](#) is connected to compressed air supplies or operated with compressed air (3-8 bars), respectively. Mode of operation is based on the principle of a vortex tube, in which two opposite rotating air flows will be generated. At the blue component output of the internal flow as usable cold air (up to  $-25^{\circ}\text{C}$ ) takes place; at the red component output of the hot air (up to  $100^{\circ}\text{C}$ ) takes place. The needle valve allows adjustment of volume flow and portion of cold air.

Accessories for the Ariana cold air nozzle include the flexible [ARIANA-Cool-Line-System](#) and also a magnet plate, ball cock, grommet for quick coupling and also a sound absorber.

## Functional diagram

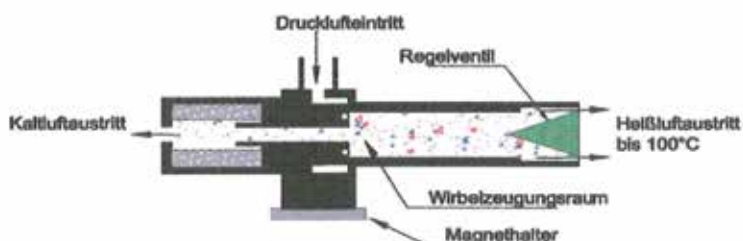



## Power Vac Pump



The **ARIANA Power Vac Pump** is a dual-acting suction and pressure pump that uses compressed air. It is mainly used for filling and emptying lubricant and coolant tanks. The pump was designed for fast and trouble-free installation at standard barrels. It is screwed into the bung hole of the barrel and connected to the compressed air supply. A feed hose is attached at the other barrel opening.

The Power Vac Pump requires compressed air at approx. 8 bar. This makes it possible to fill or empty at approx. 60 l/min. An automatic closing valve serves as an inlet/outlet control and thus prevents overflows.

The Power Vac Pump generates a vacuum in the tank, as a result of which it is possible to suction used coolants, mud, metal residues, etc. out of machine tanks as well as excess liquids out of chemical tanks.

By simply turning a knob, the operator can reverse the function and generate overpressure in the tank, as a result of which it is possible to pump lubricants and coolants as well as liquid chemicals into the machine. The Power Vac Pump can also be used in explosion-protected areas.

Order no. 0321000

### The following accessories are included with the Power Vac Pump:

- Ascending pipe
- Threaded barrel connector 2"
- Fast-action connector
- Feed hose 3 m.
- Suction pipe



Order no. 0389001



## Micro-System



The [ARIANA Micro System](#) for minimum quantity lubrication uses a coaxial spray nozzle to produce a round spray with spraying angle. It is possible to produce different spray cones for many application areas by rotating the cap.

The coaxial spray nozzle is operated pneumatically and is supplied with the medium by means of a separate, unpressurized tank.

The spray nozzle has been adapted for hard to access applications with the [ARIANA Cool Line System](#).

Many different liquid products can be sprayed thanks to the system's special jet technology, from water-miscible cooling lubricants to viscous cutting and drawing oils.

Order no. 0551000

### Technical data

Compressed air supply	approx. 8 bar
Medium	28 – 500 cSt
Flow rate	5 – 40 ml/min.
Air consumption at approx. 8 bar	100 l/min.



## Chip Hook



Order no. 0541500    Length 175 mm  
Order no. 0541300    Length 300 mm  
Order no. 0541400    Length 500 mm

### Chip hook with guard and tip at 90° angle

#### Accessories:

Item No. 0541309-2    Shovel for chip hook



### Application area:

For removing chips that are hard to reach.  
The guard protects your hand from injury.



## Magnetic Sweeper with protection shield

Order no. 0541801



### Application and operation:

To collect and remove chips and small parts from hardly accessible places. The integrated permanent magnet of the sweeper attracts all magnetic materials. By pulling out the handle of the permanent magnet, the chips fall off and can easily be stripped into the collecting box. The protective shield at the end of the handle avoids possible injury.

- universal and mobile use at hardly accessible places
- safe and clean working environment
- reduced risk of injury from sharp edged chips due to the protection shield
- automatic separation of materials

### Specifications

- long durability due to stainless steel housing and powerful permanent magnets
- adjustable rod length
- convenient dimensions: 360-675 mm length, 25 mm diameter
- lightweight: 554 g
- Holding capacity: 19,3 kg





## Barrel key



Order no. 0512115

Barrel key

- made of steel
- fits all saleable bung lids
- safe and easy opening due to fitting tools



## Overflow Protection Siren



Item No. 0513512

Our [ARIANA overflow protection siren](#) is an important accessory for every CNC machine which is filled with emulsion or oil. The overflow protection siren is signaling overflowing by an audible and optical signal. The level in the fluid container can be changed by adjusting the modular hose. Flooding is signaled by the acoustic warning siren.

The double function can be activated by turning the liquid level switch. Once the filling volume of the basin is getting low the overflow protection siren is switching on. To prevent that the supply pump is running empty a signal indicates that the minimum liquid level is achieved.

### Advantages:

- Acoustic liquid level control at your machine tool
- No unnecessary and time-consuming cleaning of your production hall
- Very good monitoring of the minimum or maximum filling level
- Easy fixing through magnetic base
- Operating with a 9V monoblock battery



## Pneumatic Oil Boost Pump



Order no. 0541091

Boost pump with high flow rate for simple and fast filling flexibility thanks to mobile trolley.

### The following accessories are included with the Pneumatic Oil Boost Pump:

- Trolley for 180 kg drums
- Flow volumeter
- High-pressure gun
- 3.5 m high-pressure hose

Suitable for oils ranging from VG 10 to VG 460 at 40°C  
Required operating pressure: approx. 6 bar



## Pneumatic Oil Boost Pump



Order no. 0541091

Boost pump with high flow rate for simple and fast filling flexibility thanks to mobile trolley.

**The following accessories are included with the Pneumatic Oil Boost Pump:**

- Trolley for 180 kg drums
- Flow volumeter
- High-pressure gun
- 3.5 m high-pressure hose

Suitable for oils ranging from VG 10 to VG 460 at 40°C  
Required operating pressure: approx. 6 bar



## THREAD-CUTTING AGENT 0802850



### PRODUCT DEFINITION

This advanced multi-purpose lubrication of the latest generation will be applied directly from the spray bottle onto the metal surface to be processed and will cause a significantly longer service life of the tools. This semi paste-like grease is ideally suited for all metals, even stainless steel. The product does not contain mineral oil, chlorine or sulphur.

### PROPERTIES

0802850 is a paste on water/soap basis and ideally suited for thread-cutting, tapping, centring, removing and milling.

### APPLICATION

The thread-cutting product must be used in pure condition. It does not leave an oily surface. Thus a clean work environment is the result.

### TECHNICAL DATA

Colour	light bluish
Odour	neutral
Condition viscosity	paste-like
Flash point	> 225°C
Melting point	32 °C

SEC-DE160702615-08/07

SE-Cert GmbH  
Reg.-No. DE245992651

# Zertifikat

Zertifikat über die Anerkennung eines Managementsystems nach DIN EN ISO 9001:2008

Certificate for an approval of a management system according to  
DIN EN ISO 9001:2008

Zertifikatsinhaber: **ARIANA Industrie GmbH**  
Holder of Certificate: **Zum Lausbühl 3**  
**79227 Schallstadt**

Geltungsbereich: **Entwicklung, Montage und Vertrieb von**  
Scope: **Kunststoff-Gelenkschlauchsystemen**  
**für Werkzeugmaschinen,**  
**Kühlschmierstoffwartungsanlagen und**  
**Dosiereinrichtungen**



Der Zertifikatsinhaber hat nach SES 45012 T2 alle notwendigen Nachweise erbracht,  
dass ein Managementsystem nach DIN EN ISO 9001:2008 wirksam ist.

The holder of certificate has adduced all required evidence according to the SES 45012 T2 in order to prove that an effective  
management system is implemented according to  
DIN EN ISO 9001:2008.

**SECert**

Hinter dem Dorfe 2b  
D-31162 Bad-Salzdetfurth

Leiter der Zertifizierungsstelle  
Dipl.-Ing. Stephan Eierund

Gültig ab: **23.08.2016**  
Valid from:

Gültig bis: **22.08.2019**  
Valid to:

Rev. A

## NSF International

RECOGNIZES

**ARIANA Industrie GmbH**  
Germany

AS COMPLYING WITH THE NSF REGISTRATION GUIDELINES FOR PROPRIETARY  
SUBSTANCES AND NONFOOD COMPOUNDS, PRODUCTS APPEARING IN THE  
NSF OFFICIAL LISTING ARE AUTHORIZED TO BEAR THE NSF REGISTRATION  
MARK.



Nonfood Compounds  
Program Listed

This certificate is the property of NSF International and must be retained upon request. For the most current and complete information, please access NSF's website (www.nsf.org).

October 22, 2014  
Certificate# CR207065 - 01

Sarah Kroll  
Global Managing Director, Food Safety Product Certification





# ARIANA

ARIANA Industrie GmbH

Staufener Str. 2

79427 Eschbach

Tel. +49 (0) 7664/50 99 00 - 0

Fax +49 (0) 7664/50 99 00- 99

[info@ariana-industrie.de](mailto:info@ariana-industrie.de)

[www.ariana-industrie.de](http://www.ariana-industrie.de)

... A strong Team with our partners.

